

PALLMANN

Granulating of Plastics

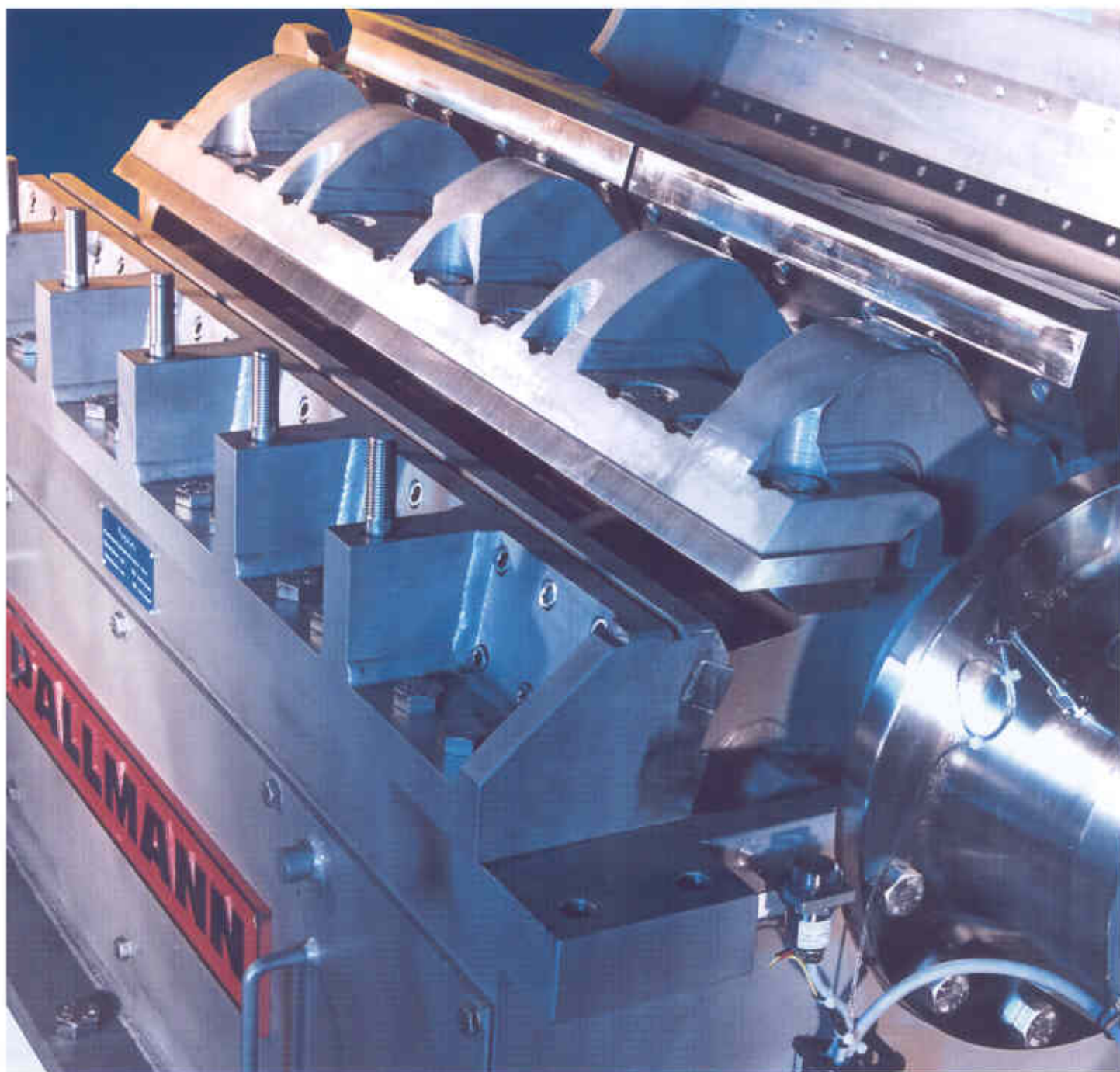

Granulating of Plastics

100% Utilization of Plastics

Knife mills play an important role in the production and processing of plastics of any kind. The preparation of production waste, reintroduced into new production, guarantees considerable cost saving.

Resources are protected due to the preparation of already used plastics such as film- bottle- and profile waste etc.

In order to optimally meet the various requirements, PALLMANN – the specialist for knife mills – offers one of the broadest scopes of supply. Almost 100 standardized machine types and sizes are available.

PALLMANN Ultra-Granulators™ are used in extrusion for the production of profiles, sheets and film, in injection- and blow- moulding as well as by sub-suppliers of the automobile industry.

Besides the many standardized applications, PALLMANN Ultra-Granulators™ are used for size reduction of heat-sensitive rubbers and elastomers, highly rigid fiber waste or very abrasive products.

Furthermore, PALLMANN Ultra-Granulators™ are widely spread throughout the chemical- and recycling industry.

Due to the variety of materials, their form and constitutions, PALLMANN supplies machine technology suited for the corresponding application.

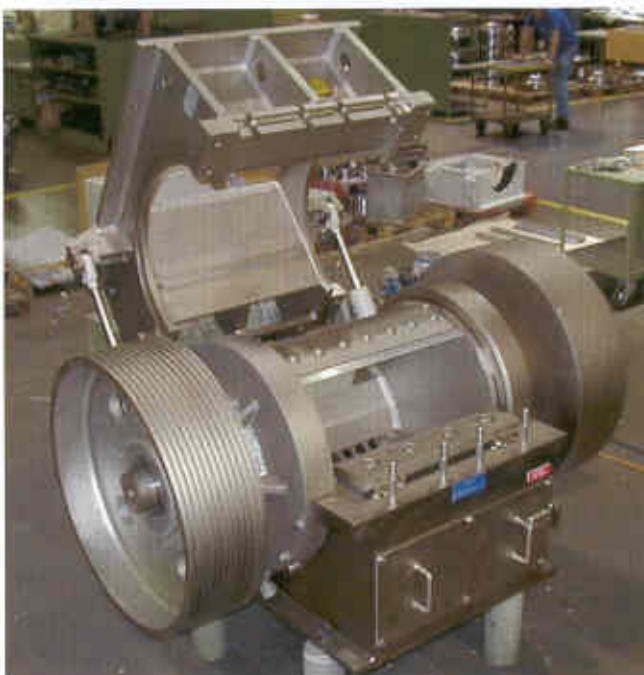

All PALLMANN Ultra-Granulators™ stand out due to a robust welded construction, Electro-dynamically balanced rotors and simple maintenance. High throughput rates at high availability are achieved in rough, every day production.

The use of special materials such as stainless and polished steels as well as chemical nickeling for corrosion protection are available as well as gas- and pressure-sealed designs and adherence to factory-specific standards or ATEX-recommendations etc.

PALLMANN, designs and manufactures complete systems that were coordinated, together with the customer, to his individual requirements and local conditions.



Sucess by utmost Care for Details

PALLMANN supplies Ultra-Granulators™ that offer optimum prerequisites in the broadest spectrum of application fields.

Depending on the requirement, different varieties of machine housings with various numbers of knives and cutting geometry are available. These range from machine housings with two rows of knives for the size reduction of thin-walled parts and bulky hollow pieces up to machine housings with three or four rows of knives for the size reduction of compact parts such as lumps, sheets, film, fibers or for high throughput rates.

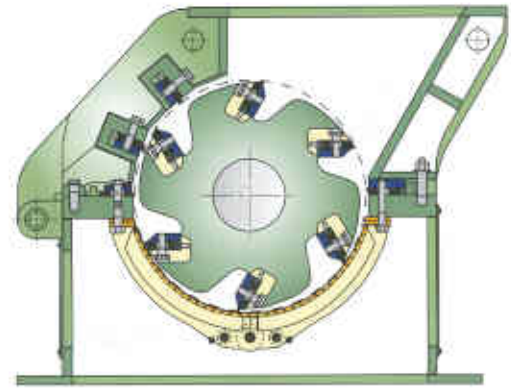
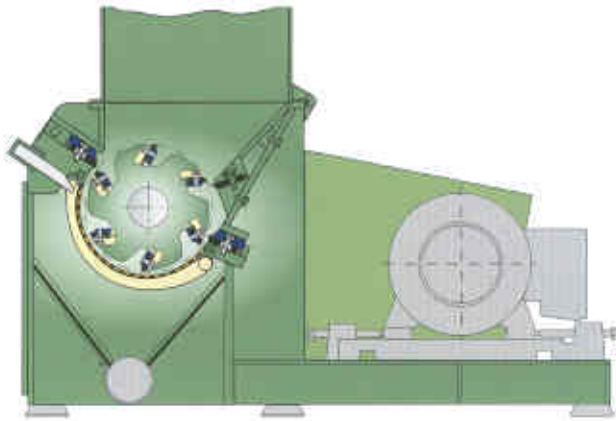

The types and designs of the rotors are as versatile as the types of applications. From open guillotine rotors for heat-sensitive products up to closed and partially water-cooled multi-knife rotors for pulverization, PALLMANN's scope of supply fills all desires.

PALLMANN Ultra-Granulators™ produce high quality granules at low cost by choosing the correct cutting technology. For easy handling, PALLMANN Ultra-Granulators™ have a split housing and can be, depending on the design, manually or hydraulically raised or lowered.

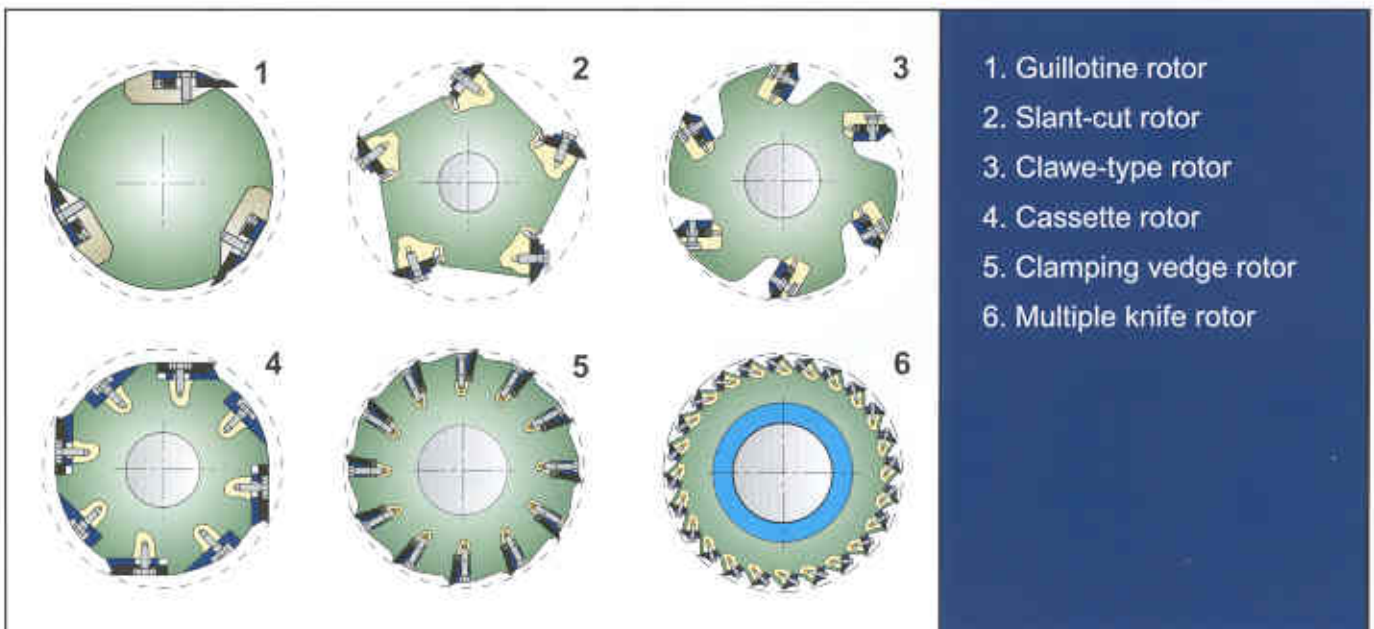

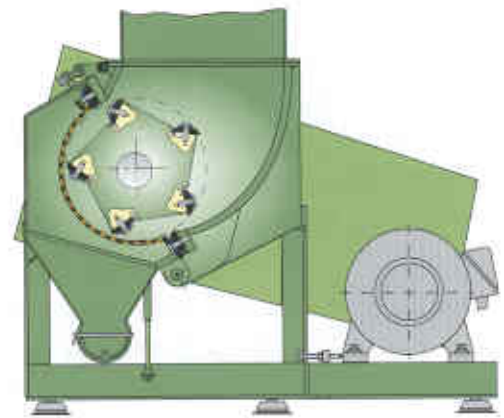
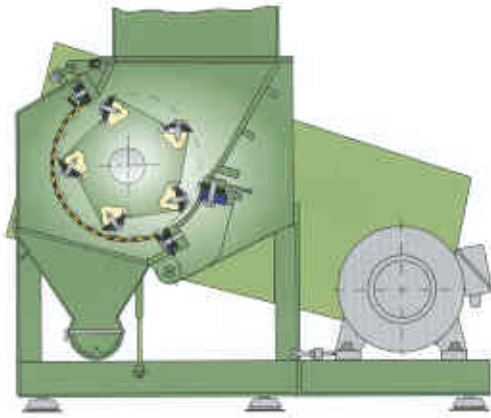

The screen inserts are easily accessible and are available with either square or round holes.

In order to achieve a high quality end product, at low operating costs, an exact cutting gap between the rotating and the stationary knives is required.

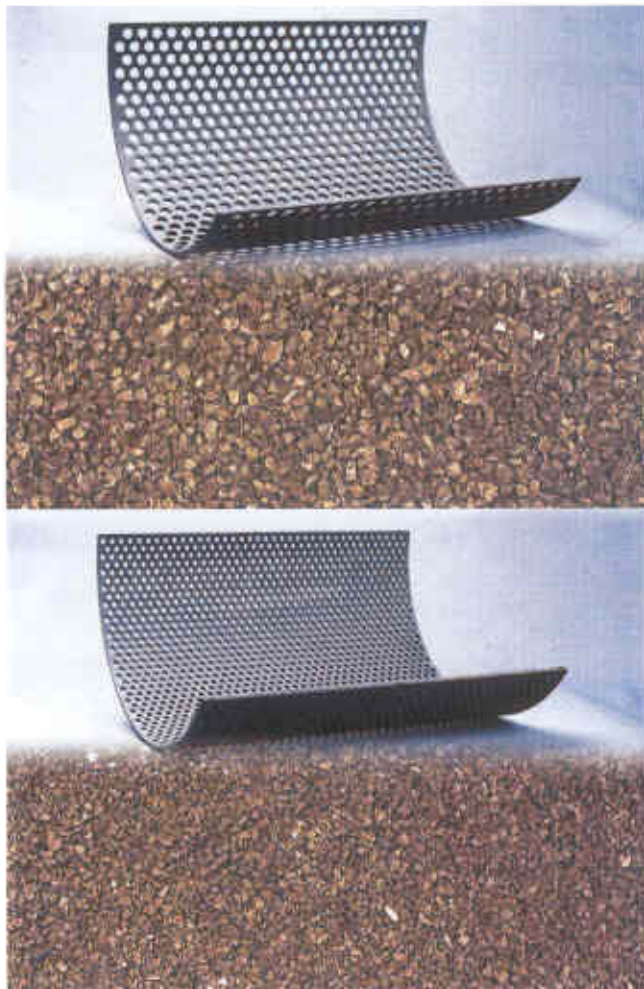

Knife-setting is essential

In Ultra-Granulators™ size reduction is effected between rotation and stationary knives. The more precise the cutting gap between the knives is adjusted, the higher the product quality and the lower the operating costs

PALLMANN Ultra-Granulators™ always offer the advantage of rotor- and stationary knives being precisely set in a fixture outside of the machine while a second set of knives is installed and operating in the machine. The downtime of the machine for knife changing is therefore reduced to the time required for removal of dull knives and installation of sharp knives only. There is no setting or adjustment work to be done inside of the machine.

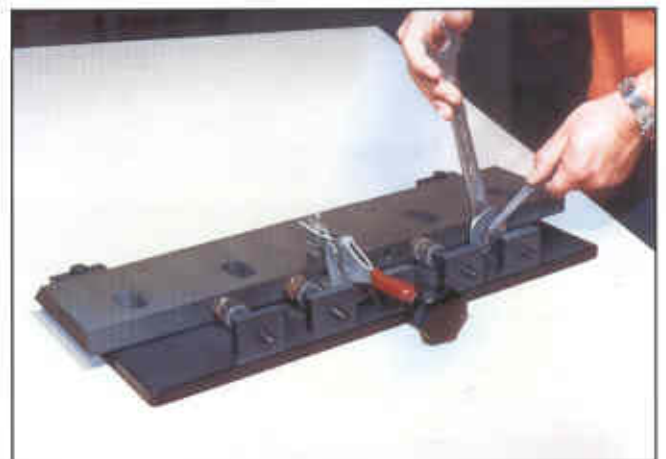

Injection moulding

The economical size reduction for inline- as well as offline-recycling of sprues and thin-walled rejects from tough elastic to brittle plastic requires special knife mills.

Compact design with a low feed height, reliable and quiet during continuous operation, quick and easy cleaning when changing products, reasonably priced and low operating costs. PALLMANN Ultra-Granulators™, series L, LX and K are specifically designed for the requirements of the injection moulding industry. Feeding can be performed by means of sprues puller systems, with conveyor belts and part separators or by hand. The product is discharged into a collecting bin, designed for standard vacuum-conveying systems or pneumatic vacuum-pressure conveying systems.



Technical Data

Type		PS-L 180x120	PS-L 180x300	PS-LX 300x400	PS-LX 300x800	PS-K 200x300	PS-K 300x300	PS-K 400x500
Infeed opening	mm	350x250	350x350	400x400	400x800	206x306	306x306	408x508
Rotor \varnothing	mm	180	180	300	300	200	300	400
Rotor type		T 3	T 3	T 3	T 3	SS 2	SS 3	SS 3
Motor	kW	2,2	4	7,5	15	4-7,5	7,5-15	22-45
Throughput rate	kg/h	20-30	50-90	80-120	160-240	90-120	160-260	250-800



Blow-moulding

For the economical size reduction of blebs and rejects, occurring during the blow moulding process, PALLMANN offers specially developed Ultra-Granulators™, series K and H.

A compact design and integrated sound insulation allow installation directly next to the production machine or as a centrally located unit.

Thermoforming

During the manufacturing of thermoformed packaging materials, skeletons occur continuously that are size reduced directly inline using the PALLMANN developed Ultra-Granulators™ series T.

The start-up film waste and/or skeletons are directly fed into the Ultra-Granulator™ via a draw-in device whereby an upstream reversing system transforms the advance cycle of the thermoform-line into a continuous feeding of the Ultra-Granulator™.

The compact design and easy accessibility for cleaning during material change and maintenance are decisive characteristics of the PALLMANN Ultra-Granulators™, series T.

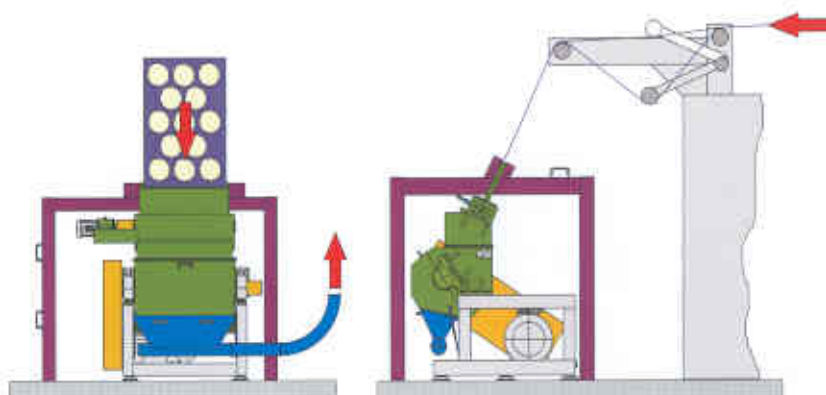

Technical Data

Type		PS-K 300x500	PS-H 400x700	PS-H 500x900	PS-H 600x900	PS-H 800x1100	PS-H 1020x1425	PS-T 300x900	PS-T 500x900	PS-T 500x1400
Infeed opening	mm	306x508	408x715	508x915	610x915	815x1120	1020x1425	405x850	508x850	508x1350
Rotor \varnothing	mm	300	400	500	600	800	1000	300	500	500
Rotor type		SS 3	FW 4	FW 4	FW 6	FW 6	SD 9	SD 3	SD 5	SD 5
Motor	kW	11-22	30-55	45-75	45-75	75-132	110-160	15-30	37-55	75-90
Throughput rate	kg/h	180-300	300-1100	400-1600	500-1800	800-2900	1100-4000	400-650	650-1300	1000-1650

Size reduction of pipes

Production waste, as well as rejected pipes, pipe bends, socket ends etc., occurring during the manufacturing of plastic pipes, can be economically size reduced, at low cost, with PALLMANN pipe crushers.

Depending on the feed material and the local conditions, the material can be fed horizontally or via a feed chute, installed at ground level, with an integrated load-controlled pusher. For these cases, the PALLMANN pipe crusher, type PSR is used.

If the machine is installed in a basement or in a pit, feeding can be performed by means of a hydraulic tipping chute. For this application, PALLMANN pipe crushers, type PS-R are used. Both series stand out due to their robust design, easy accessibility and simple handling. Material feeding is performed load-controlled by current consumption of the main motor.

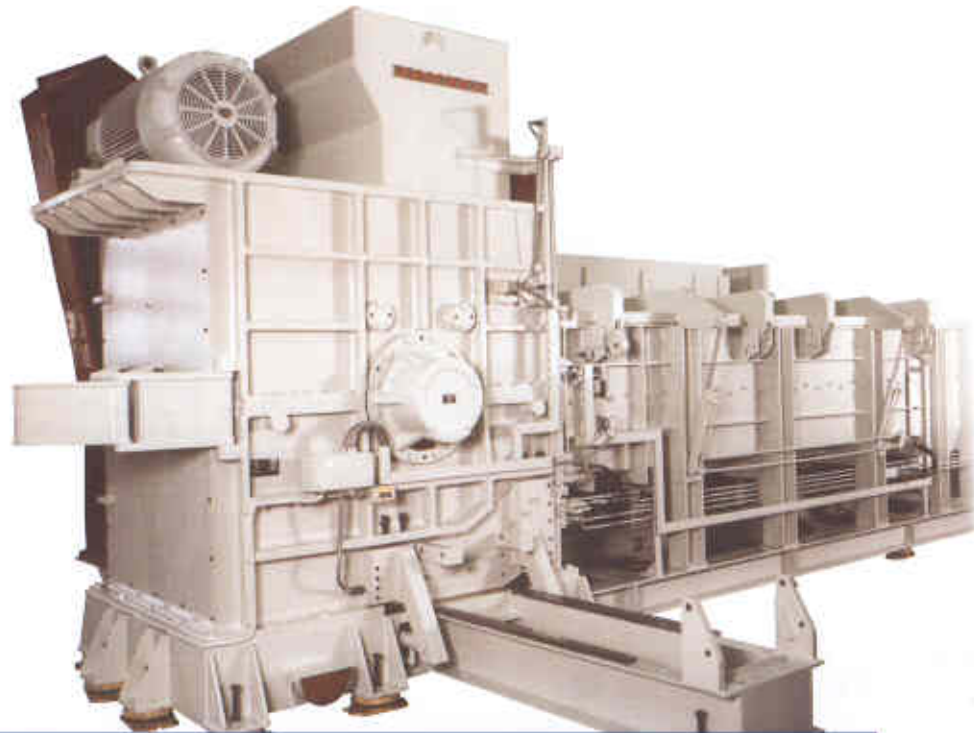

Technical Data

Type	PSR 6-6	PSR 8-6	PSR 12-8	PSR 16-12	PSR 22-18	PS-R 600x900	PS-R 800x1100	
Cuting cross-section	mm	360x560	575x560	755x750	1000x1150	1650x1700	480x550	760x850
Rotor \varnothing	mm	600	800	1200	1600	2200	600	800
Rotor type		FW 6	FW 6	FW 8	FW 10	FW 16	SD 5	SD 7
Motor	kW	75-90	90-110	132-160	160-250	315-500	75-90	110-132
Throughput rate	kg/h	600-2000	800-2300	1200-3600	1600-5000	3000-12000	500-700	850-1200



Size reduction of profiles

Production waste and cut-offs from the manufacture and preparation of items such as windows, shutters, siding profiles etc., are size reduced using the PALLMANN Ultra-Granulator™, series PSP. The horizontally fed profiles are automatically drawn in by means of the specially designed rotor. Short waste pieces can be fed either by conveyor or from the top. Size of the granulated material is determined by the screen hole size.

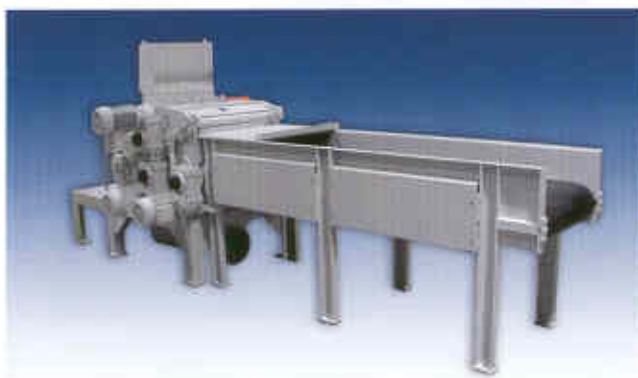

Size reduction of sheets

Waste and rejects, occurring during the manufacturing and processing of sheets, whether massive or foamed can be size reduced by means of PALLMANN Ultra-Granulators™, type PHK into granules of defined size. A controlled material feeding via the upstream conveyor belt with a simultaneous horizontal feeding is possible due to the integrated draw-in rollers.

Technical Data

Type		PSP 400x500	PSP 400x700	PSP 500x700	PSP 600x900	PHK 120x700	PHK 200x1400	PHK 300x1050
Infeed opening	mm	185x460	185x650	245x650	305x850	120x700	200x1400	300x1050
Rotor \varnothing	mm	400	400	500	600	400	600	800
Rotor type		SW 8	SW 8	SW 8	SW 10	F 5	F 5	F 7
Motor	kW	37-45	37-55	37-55	45-75	45	75-110	110-160
Throughput rate	kg/h	400-1200	600-1500	600-1500	900-2000	500-3000	1000-6000	1500-9000

Size reduction of rubber

For the economical size reduction of natural and synthetic rubber of any kind in form of bales, sheets or chips, vulcanized or unvulcanized, with or without textile reinforcement, PALLMANN offers Ultra-Granulators™, series PS-C.

PALLMANN has specifically designed guillotine rotors, in completely open design without central rotor shaft and with high rotor inertia. Thanks to the patented feeding system, also extremely difficult temperature-sensitive materials can be reduced in size. Well proven metering and recovery systems are available for any type of application.

Standard one-, two- or three-step size reduction systems can be offered. We specialize in custom-designed complete production lines.

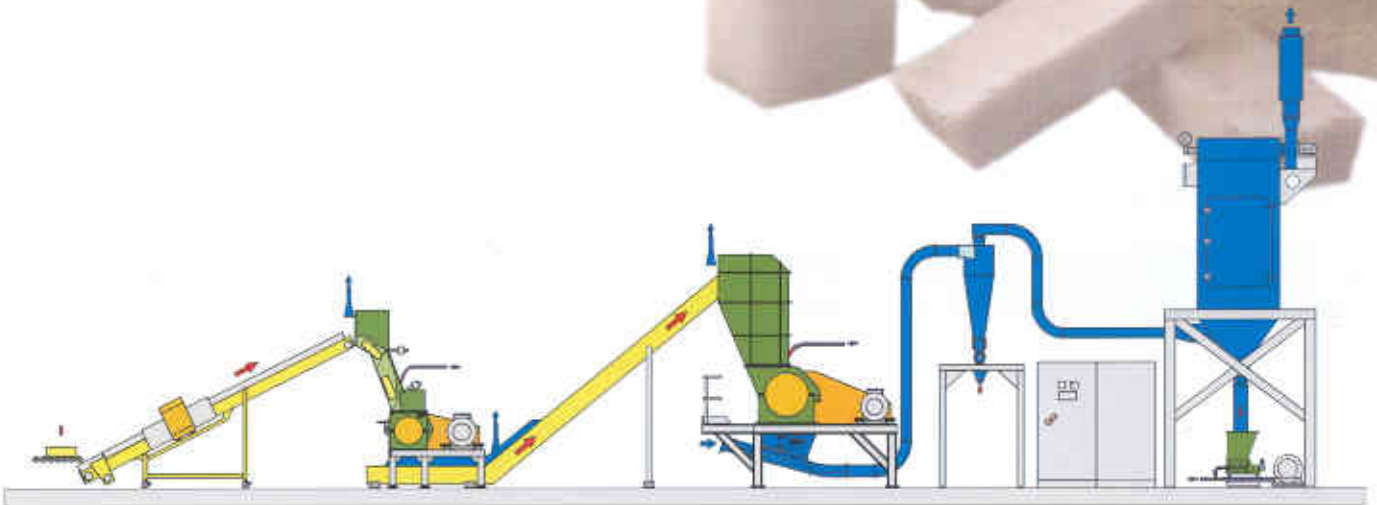



Guillotine rotor.

Technical Data

Type	PS-C	4-5	4-7.5	4-10	6-6	6-9	8-6	8-9	8-12
Infeed opening	mm	510x500	510x750	510x1000	560x630	560x930	820x625	820x930	820x1250
Rotor \varnothing	mm	400	400	400	600	600	800	800	800
Rotor type		G3	G3	G3	G3	G3	WG6	WG6	WG6
Motor	kW	37-55	55-90	75-110	55-90	90-132	90-132	110-200	132-250
Throughput rate									
Pre-cutting	kg/h	800-4000	1100-5500	1500-7000	1200-6500	1700-9000	1500-8000	2200-11000	3000-15000
Throughput rate									
Granulating	kg/h	200-2000	300-2500	400-3750	350-3000	450-4000	450-3500	600-5300	800-7000

Film recycling

Rationalization of production and recycling of high value raw materials are some of the most important goals of any future-oriented film producer.

The utilization of PALLMANN film recycling systems is an important building block of a modern, efficient production organization. Film recycling requires the know-how of specialists. PALLMANN offers specific know-how for continuous, trouble free recycling of trim waste as well as for film rolls, film packets, loose and tangled film and sheets.

In order to make most profit, the choice of equipment and the total preparation concept are important.



Knife mill for edge trimmings



Knife mill for Film, type PS-F

Technical Data

Type		PSF 200x150	PSF 200x450	PS-F 3	PS-F 3,5	PS-F 4-5	PS-F 4-7,5	PS-F 4-10	PS-F 4-12,5
Cutting chamber	mm	100x150	100x450	260x250	300x450	350x500	350x750	350x1000	350x1200
Rotor \varnothing	mm	200	200	230	320	400	400	400	400
Rotor type		GS 2	GS 2	S 3	GS 3	GS 3	GS 3	F 5	F 5
Motor	kW	2,2	4,0	5,5-7,5	11-22	18,5-45	22-55	75-110	110-200
Throughput rate	kg/h	100-1000	250-3000	40-180	80-380	150-660	220-990	320-1480	400-1850



In addition, a number of technical details have to be observed such as the design of the pneumatic conveying system with its important components, separation of material and conveying air in special cyclones, choice of the most appropriate feed roller system, choice of appropriate film silos for guaranteed trouble free storage and discharge of the film chips.

The size reduction of film is a tough application for knife mills. The typical 24 hour operation and the high cutting forces required for film cutting call for optimized design of the knife mill with regard to high precision in manufacturing, mechanical stability, performance and ease of servicing.

PALLMANN Ultra-Granulators™ set the standard.

Knife mill, type PSRH



Industrial Granulator, type PS 8-12

Technical Data

Type		PS-F 6-9	PS-F 8-12	PS-F 8-15	PS-F 8-18	PSRH 6-6	PSRH 6-9	PSRH 6-12	PSRH 6-15
Cutting chamber	mm	550x900	750x1200	750x1500	750x1800	480x600	480x900	480x1200	480x1500
Rotor Ø	mm	600	800	800	800	600	600	600	600
Rotor type		FW 6	FW 8	FW 12	FW 12	GW 4	GW 4	GW 4	GW 4
Motor	kW	75-110	110-200	132-250	160-250	45-55	75-90	90-110	110-160
Throughput rate	kg/h	400-1780	700-3000	40-180	80-380	300-1300	500-200	650-2600	800-3200

Industrial Granulators

Larger and more efficient knife mills are required due to the production of steadily increasing plastic parts, as well as the increasing demand for products from any field of the plastic- and chemical industry also from private consumption and the thereby resulting material quantities which are to be recycled in-house or as valuable material.

PALLMANN's decades of experience in manufacturing these machines guarantees decisive competitive advantages.

PALLMANN supplies industrial granulators, specifically adapted to each application, that reliably size reduce anything which can be cut. PALLMANN industrial granulators are, corresponding to the requirement, generally designed in fully welded steel construction, the rotors are stress-relieved, precisely manufactured and electro-dynamically balanced.



Industrial Granulator, type PS-I



Industrial Granulator, type PS-B

Technical Data

Type	PS-I 6-6	PS-I 6-9	PS-I 8-6	PS-I 8-9	PS-I 8-12	PS-I 8-15	PS-I 12-12	PS-I 12-18
Infeed opening mm	600x600	600x900	800x600	800x900	800x1200	800x1500	1200x1200	1200x1800
Rotor \varnothing mm	600	600	800	800	800	800	1200	1200
Rotor type	FW 6	FW 6	FW 6	FW 6	FW 6	FW 6	FW 8	FW 8
Motor kW	55-75	75-90	75-132	90-132	110-160	132-200	132-200	200-315
Throughput rate kg/h	300-1200	500-1800	450-1600	600-2400	750-3000	900-3600	750-3600	1200-6000



As with all PALLMANN Ultra-Granulators™, the rotor knives as well as the stator knives are adjustable outside the machine in a fixture. Short machine down time during knife exchange as well as high availability are the special benefits.

Folding down screens allow easy access to the cutting chamber and thorough cleaning upon change of product. The bearing is oversized. The bearing system prevents penetration of grease into the grinding chamber and dust into the bearings.

The upper part of the housing swings open hydraulically; in any case, the necessary safety techniques allows the machine to be opened only when the rotor is at a standstill.

PALLMANN industrial granulators – the concentrated strength in size reduction.

Technical Data

Type		PS-H 600x900	PS-H 800x1100	PS-H 1000x1400	PS-H 1000x1600	PS-H 1200x2000	PS-B 630x1000	PS-B 800x1250
Infeed opening	mm	610x915	815x1120	1020x1425	1020x1625	1220x2025	638x1020	810x1270
Rotor \varnothing	mm	600	800	1000	1000	1200	630	800
Rotor type		FW 6	FW 6	SD 9	SD 9	SD 15	FS 6	FS 6
Motor	kW	45-75	75-132	110-160	132-200	160-250	55-132	75-200
Throughput rate	kg/h	500-1800	800-2900	1100-4000	1500-6000	2000-9000	600-2200	1000-3000



The PALLMANN Group of Companies

The Pallmann Group of companies is the leading manufacturer for size reduction machines and systems for the plastic and recycling industry.

Pallmann Maschinenfabrik develops and manufactures machines and complete systems according to customer requirements or as standard solutions for the preparation of almost any plastic as well as recycling products. In its headquarters in Zweibrücken, Pallmann operates one of the world's largest research and technology centers as well as a training- and service center. More than 130 different test machines are available for the preparation of a wide variety of materials. A downstream laboratory analysis of the test material as well as the preparation on a production scale is possible. In addition to the manufacturing facilities in North- and South America, the Pallmann group of companies operates a worldwide spare parts- and service network.



The PALLMANN Program

Engineering and Service:

Design and manufacturing
Research and development
Production scale testing
Laboratory analysis
Worldwide service
Spare parts
Controlling
Process Control
Installation & Start-up
Overhaul & Repair

System solutions for:

Pulverizing
Granulating
Agglomerating
Recycling

Products:

Agglomerators
Pulverizing Systems
Disc Mills
Turbo Mills
Pin Mills
Laboratory Mills
Universal Mills
Complete Grinding Systems
Knife Mills
Profile Shredders
Rubber Granulators
Pipe Crusher
Air-Swept Mills
Impact Mills
Industrial Granulators
Cryogenic Grinding Systems

Pallmann Maschinenfabrik GmbH & Co.KG
Wolfslochstraße 51
66482 Zweibrücken
Germany
Phone: +49 6332 802 0
Fax +49 6332 802 521
E-mail: plast-chem@pallmann-online.de
<http://www.pallmann.de>

Pallmann Pulverizers Co. Inc.
820 Bloomfield Ave.
Clifton NJ 07012
USA
Phone: +1 973 471 1450
Fax +1 973 471 7152
E-mail: info@pallmannpulverizers.com
<http://www.pallmannpulverizers.com>

Pallmann do Brasil ind. e Com Ltda
Av. Presidente Juscelino, 11 56
09950-370 Diadema S.P.
Brasil
Phone: +55 11 745 3044
Fax +55 11 745 4968
E-mail: pallmann@pallmann.com.br
<http://www.pallmann.com.br>

Pallmann Beijing Representative Office
Unit 13, 6th Floor of Tower A
Beijing Cofco Plaza
No.8, Jianguomennei Dajie, Dongcheng District
Beijing, China
Phone: +86 10851 6826
Fax +86 10851 6825
E-mail: info@pallmann.com.cn