

X Series Granulators

Features

- Unique rotor and disc design reduces frictional heat, helps prevent end-plate smearing.
- Exclusive Twin Shear slicing action reduces energy consumption, fines and extends knife life.
- Split chamber, easy cleanout service access.



**High-Capacity, Low-Profile
Granulators for Reclamation of
Bulky Plastic Scrap.**

X Series Granulators

Low-Heat Granulation

- Unique rotor and cutting chamber design helps prevent polymer "melt-down"
- Virtually eliminates "endplate smearing"
- End ring (disc) rotates in relationship to the cutting chamber, vastly improving airflow and minimizing frictional heat

Reduced Energy Consumption

- Made possible by the Twin Shear "scissor cutting" action knife design
- More efficient than chopping motion knife designs
- Uses lower horsepower motor without sacrificing throughput performance

Easy Accessibility and Clean Out

- Due to split chamber design which raises the upper half of the cutting chamber and lowers the screen cradle and discharge assembly via motorized screw jacks.
- 50% reduction in clean out time
- Simplifies access for knife adjustments and replacement
- Air evacuation piping system does not need to be disconnected

Low Noise Operation

- Standard double-walled hopper helps avoid the need for sound insulation rooms on plant floor

Ruggedly built to international standards, these machines will handle a wide variety of applications including bulky blow molded parts, thermoformed web and cut-sheet products, extruded sheet and film, plus the full gamut of post-consumer plastics for recycling operations.



CORPORATE HEADQUARTERS

100 Roddy Avenue
South Attleboro, MA
02703-7951
TEL: (508) 399-6400
FAX: (508) 399-6653
www.cumberland-plastics.com

Daniels Industrial Estate
Bath Road, Stoud
Gloucestershire GL5 3TJ
England
TEL: (44) 1453-768980
FAX: (44) 1453-768990

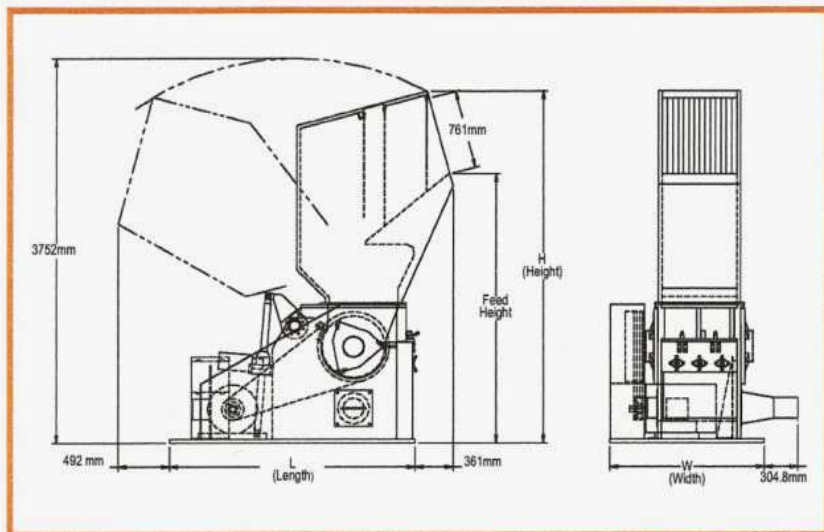

Specifications	X700	X1000	X1400
Throat Size	600 x 700 mm	600 x 1000 mm	600 x 1400 mm
Cutting Circle	600 mm		
Throughput (10 mm screen)	820 kg	1200 kg	1600 kg
Infeed	Convey		
Cutting Chamber	(2) Bed Knife Chevron		
Rotor	(3) Knife Chevron		
Rotor Knives	(6) HCHC		
Bed Knives	(4) HCHC		
Screen Diameter	10 mm		
Base	Plate Type		
Discharge	Airveyor		
Motor	37 kW (50 HP)	75 kW (100 HP)	90 kW (125 HP)
Drive	V-Belt		
Electrical Components	Safety Switches Wired into Common Junction Box		
Controls	To Suit Voltage - 110V at Operator Station		
Labels	Labels and Plates Provided for Operator Safety		
Accessories	Conveyors, Blowers, Cyclone Separators to Suit Application		
Feed height	2175 mm		
Space Envelope			
Length	2660 mm		
Width	1473 mm	1778 mm	2184 mm
Height	3429 mm		
Weight	4545 kg	5910 kg	7270 kg